

100E 10

BILOBA
UNICA

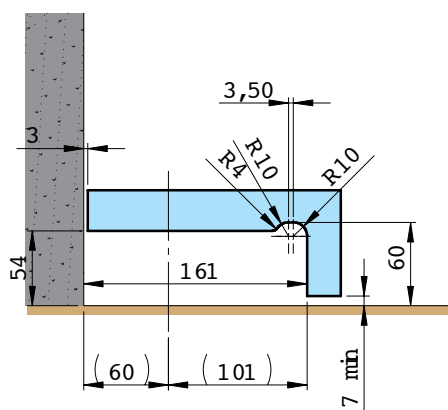

- Cerniera oleodinamica, integrata di freno e regolazioni della velocità di chiusura e dello scatto finale dell'anta. Abbinabile con tutti i patch fittings della serie Maxima. Utilizzabile anche per applicazioni pivotanti.
- Bisagra automática hidráulica, integrada de freno y ajuste de velocidad de cierre y de disparo final de la puerta. Combinable con todos los herrajes producidos de Colcom u otros. Utilizable también en aplicaciones con "punto de giro".
- Hydraulic hinge, including brake and closing speed adjustment and the end click of the leaf. Combinable with all patch fittings of the Maxima series. Useful also for pivoting applications.
- Hydraulischcharnier mit Bremse, Feststellung der Geschwindigkeit der Schließung und Feststellung der Endauslösung der Tür. Passend zu allen Produkten der Maxima Serie. Auch für schwenkenden Installationen geeignet.

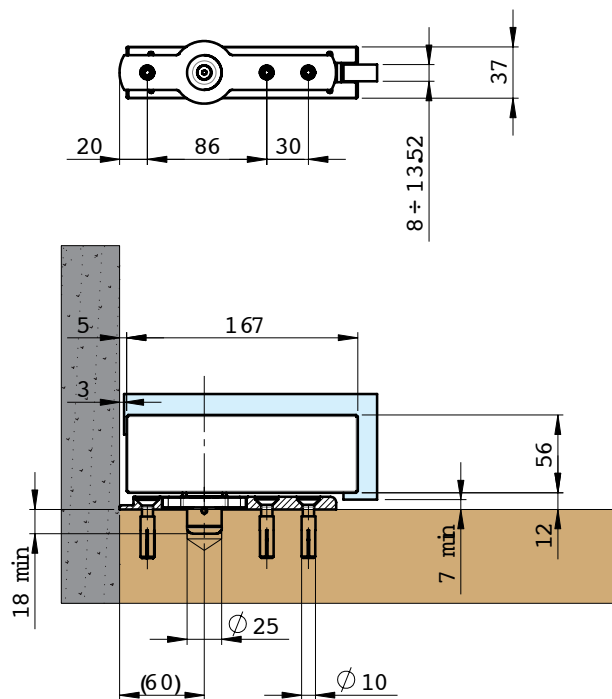
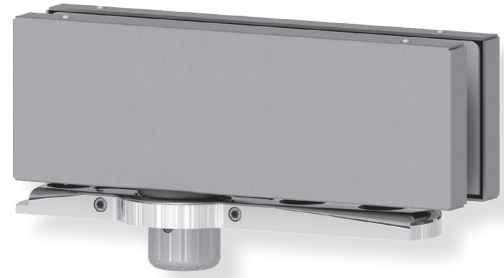

Lavorazione vetro per applicazione pivotante - Labrado del vidrio en aplicación con "punto de giro"
Glass processing for pivoting applications - Glasbearbeitung für schwenkende Installation

